

TOP VIEW

NOT TO SCALE

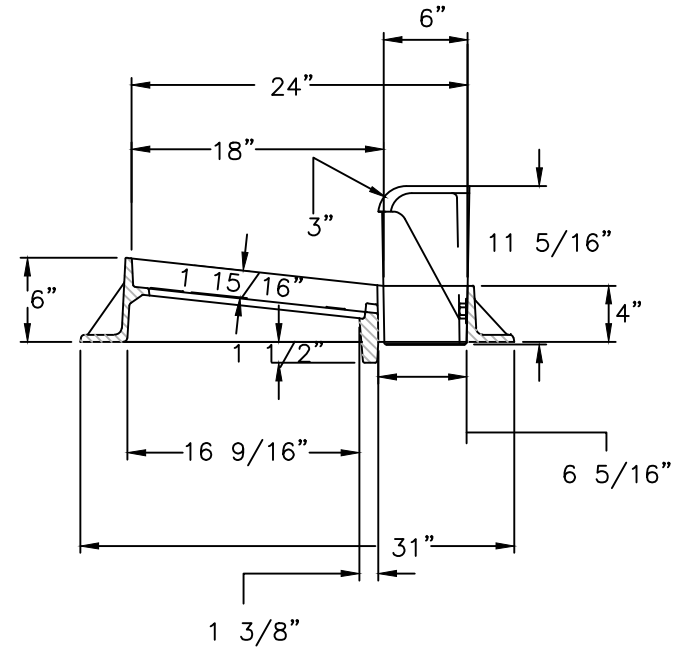

FRAME SECTION

CURB ADJUSTMENT (3-1/4" TO 9")

PRODUCT NO. 00703040B1

CATALOG NO. 7030
CATALOG NO. 7030M2
CATALOG NO. 7030T1

ALL MAT'LS GRAY IRON, ASTM CL35B

FRAME & BACK: 328 LBS
GRATE: 185 LBS
TOTAL WT: 513 LBS

MFGR: EAST JORDAN IRON
WORKS, INC.

800-626-4653

24" HOODBACK INLET
FRAME & GRATE

6.13

9/23/03	TCZ	STANDARD ESTABLISHED
9/26/06	TCZ	DEPTH DECREASED TO 24" FOR CURB & GUTTER
2/16/23	BGM	CHANGE FONT, TITLE BLOCK
DATE	BY	DESCRIPTION

North
Augusta
South Carolina's Riverfront
PUBLIC WORKS & ENGINEERING